

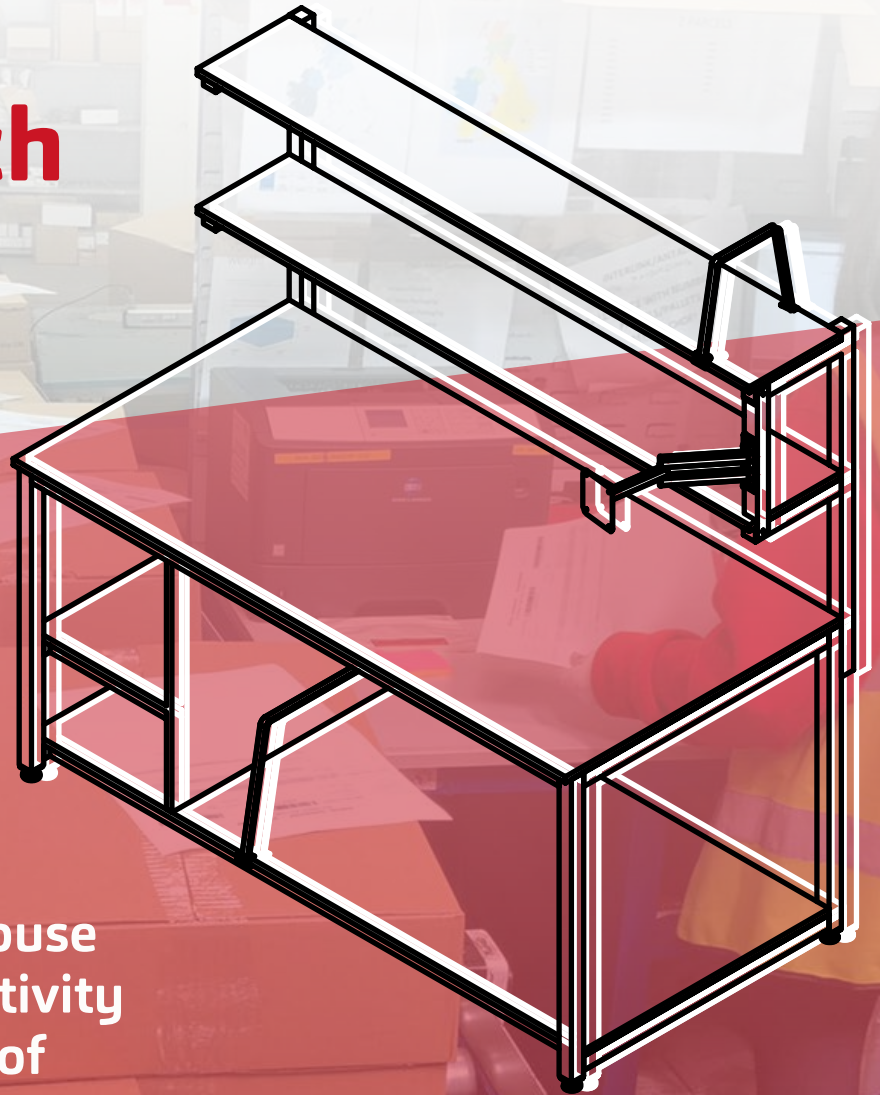

# Pack Bench Brochure



Optimise your warehouse  
efficiency and productivity  
today with our range of  
customisable pack benches

Contact us at [enquiries@southgateglobal.com](mailto:enquiries@southgateglobal.com) to  
configure your bench and get a quote

# Providing customisable solutions

Our range of customisable pack bench solutions enable you to maximise the efficiency of your space, streamlining workflow and enhancing productivity.

Our four pack benches have been created to help simplify the process of selecting customised pack benches for your warehouse. Along with the 20 optional extra parts that are available, our pack benches provide flexible solutions.

Each bench is built with a 40 x 40mm heavy-duty steel section, fully welded joints and a powder-coated finish to protect against corrosion. They are manufactured to order in Great Britain and have been designed with carefully-selected materials to ensure that they are strong and durable.

## Atlas Pack Bench

WSAtlas

Our Atlas pack bench features a fully welded box frame and four levelling feet.

- 1800 x 900 x 900mm high
- 40 x 40 fully welded box frame
- Powder-coated Ral 7001 grey
- 18mm MFC worktop

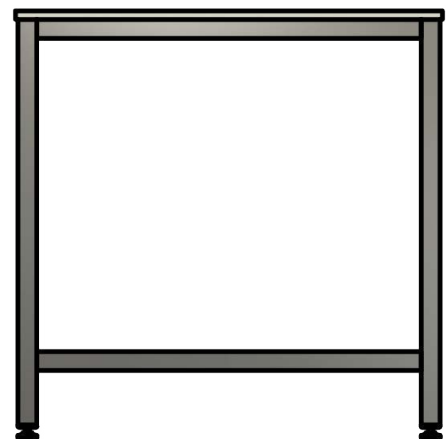
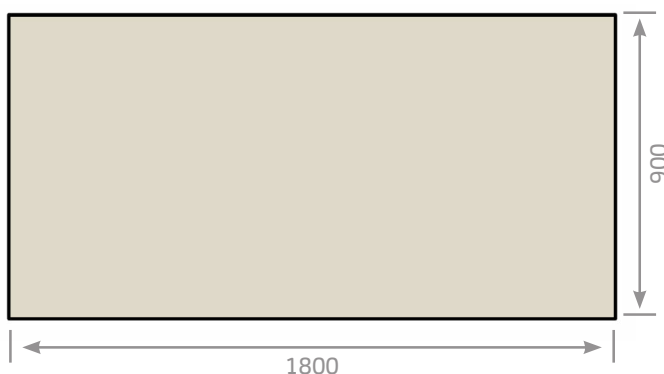
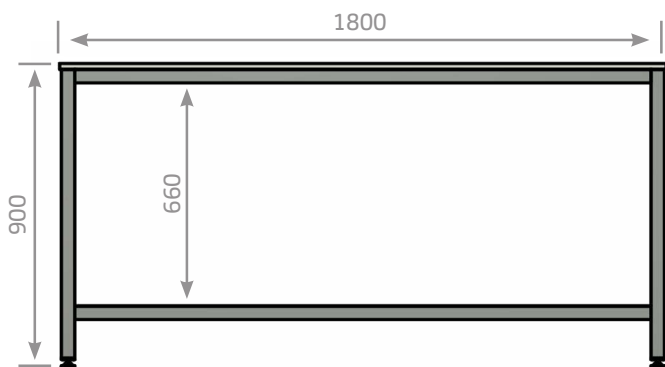
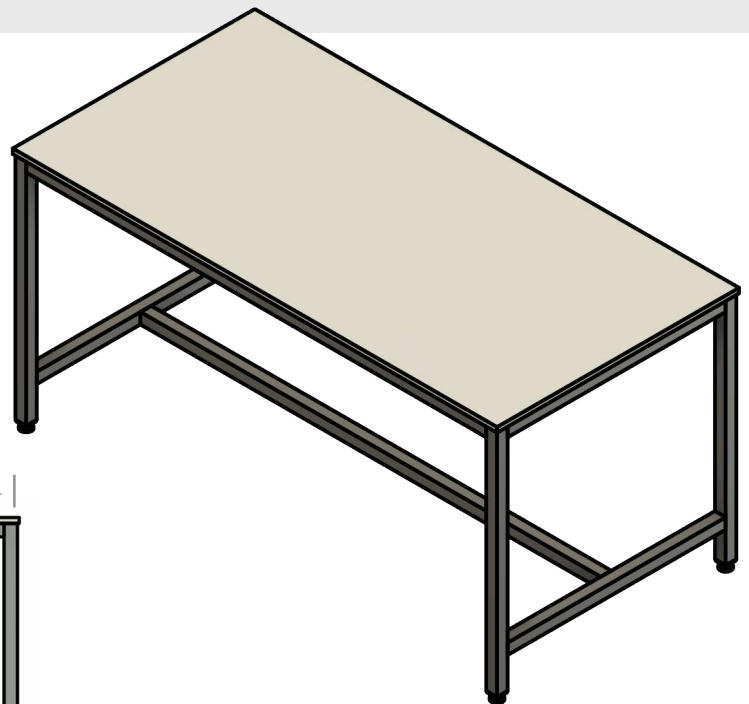

*Pack Bench Safe Weight: Worktop 150kg*

# Blakely Pack Bench

WSBlakely

Our Blakely pack bench features two over shelves, two under shelves and a monitor arm and bracket.

- 1800 x 900 x 1700mm high
- 40 x 40 fully welded box frame
- Powder-coated Ral 7001 grey
- 18mm MFC boards light grey
- Over shelves: 1800 x 300mm
- 4 levelling feet

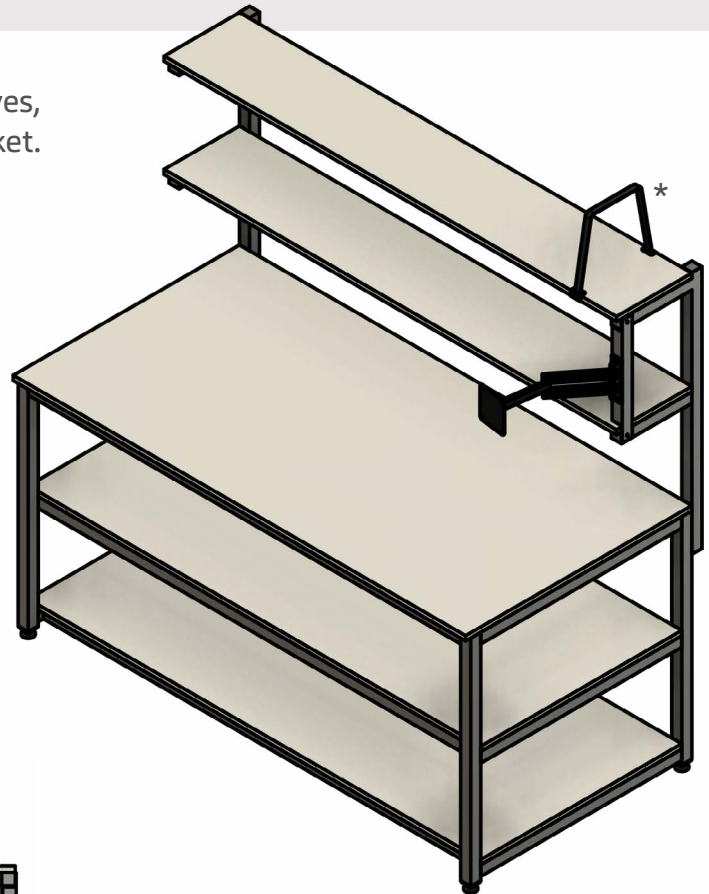

Parts with \* illustrated on the bench are for illustrative purposes only and are not included with your bench purchase.

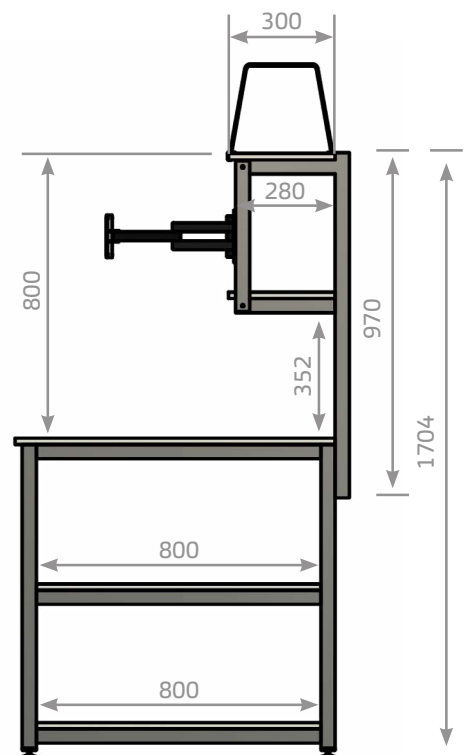
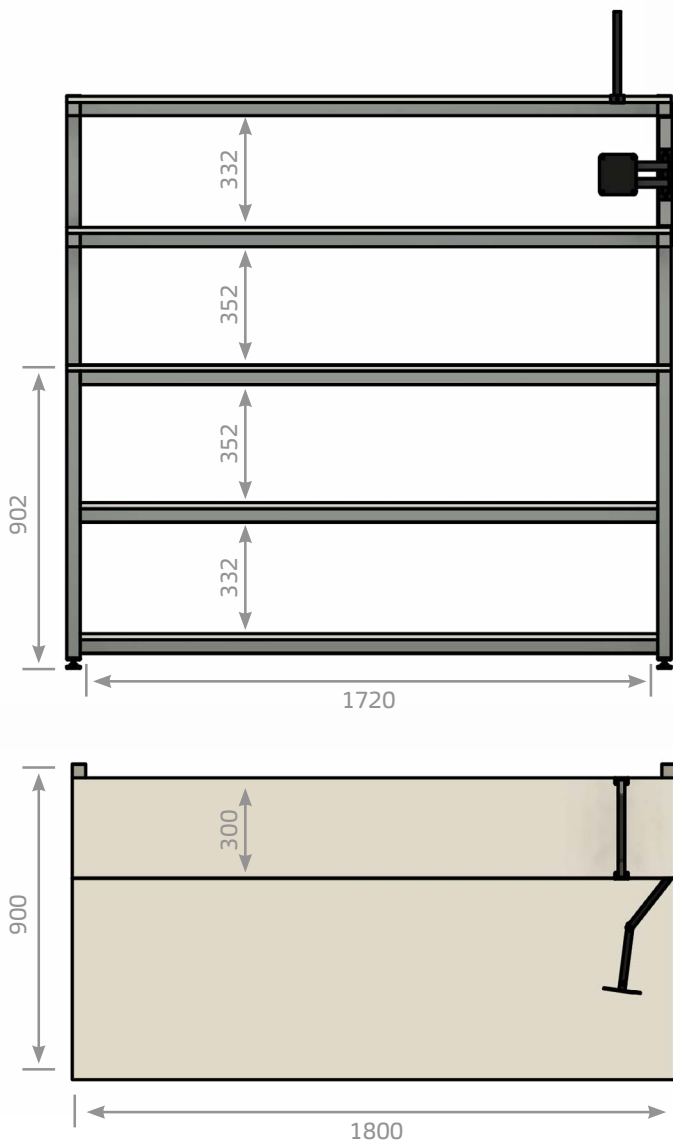

*Pack Bench Safe Weight: Lower Shelves 100kg per shelf, Worktop 150kg, Top Shelves 75kg per shelf*

# Carter Pack Bench

WSCarter

Our Carter pack bench features two over shelves, one under shelf, a printer shelf and a monitor arm and bracket.

- 1800 x 900 x 1700mm high
- 140 x 40 full welded box frame
- Powder-coated Ral 7001 grey
- 18mm MFC boards
- Over shelves: 1800 x 300mm
- Under shelf: 1800 x 800mm
- 4 levelling feet

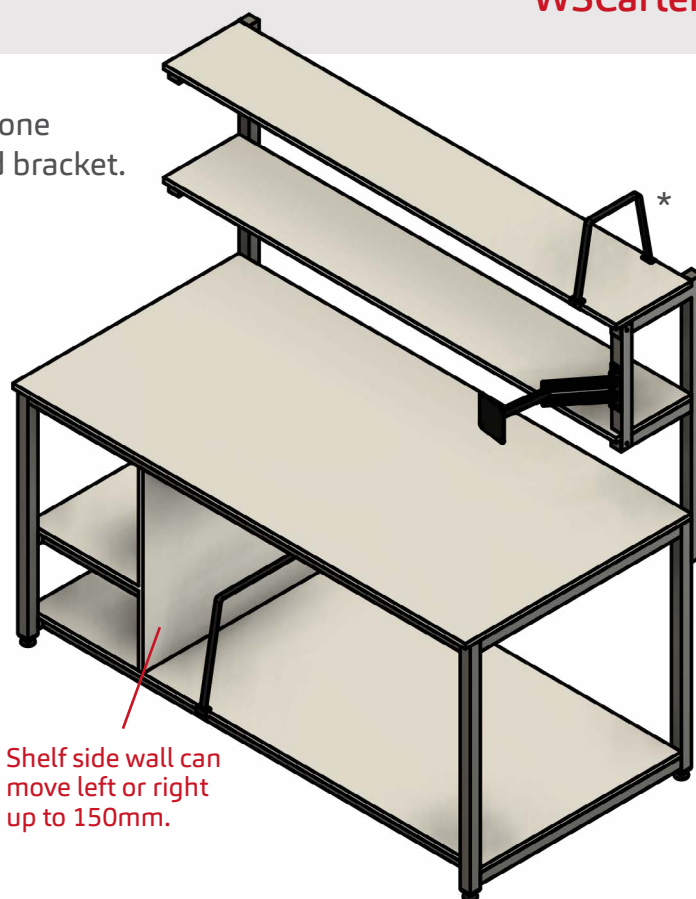

Shelf side wall can move left or right up to 150mm.

Parts with \* illustrated on the bench are for illustrative purposes only and are not included with your bench purchase.

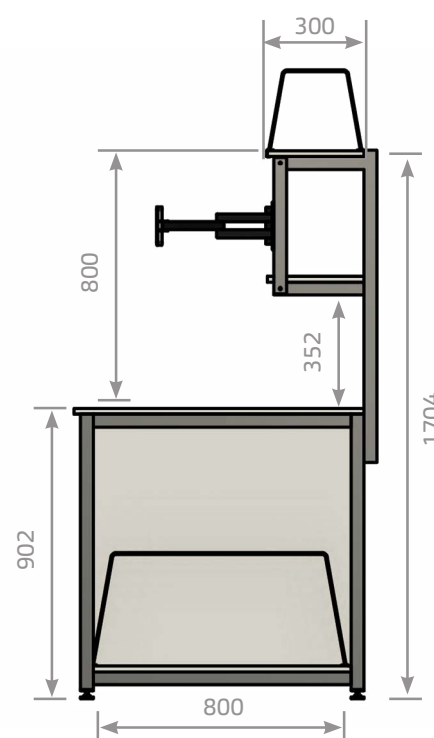
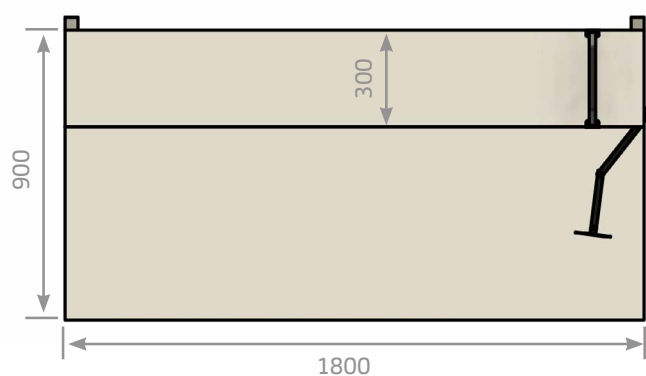
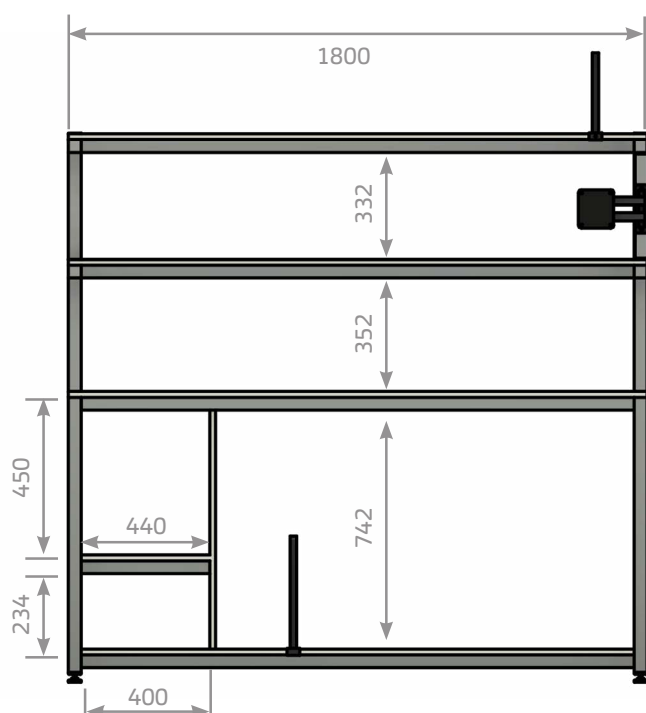

Pack Bench Safe Weight: Lower Shelves 100kg per shelf, Worktop 150kg, Top Shelves 75kg per shelf

# Darnell Pack Bench

WSDarnell

Our Darnell pack bench features two over shelves, two under shelves, a monitor arm and bracket and a box holder.

- 1800 x 900 x 1700mm high
- 40 x 40 fully welded box frame
- Powder-coated Ral 7001 grey
- 18 mm MFC boards light grey
- Over shelves: 1800 x 300mm
- Under shelves: 1800 x 800mm
- 4 levelling feet
- Box holder: 250 x 800 x 800mm

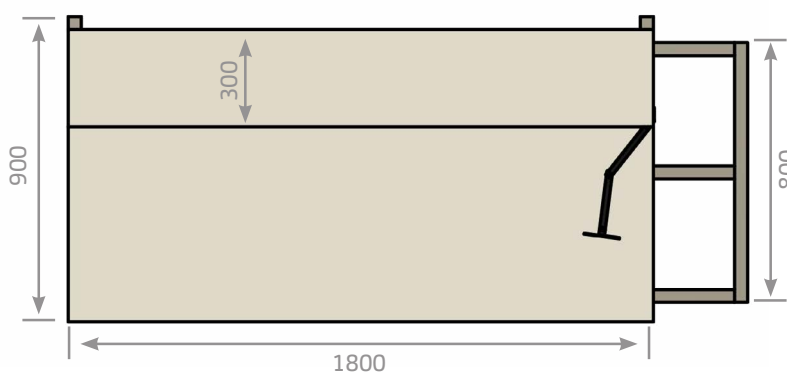
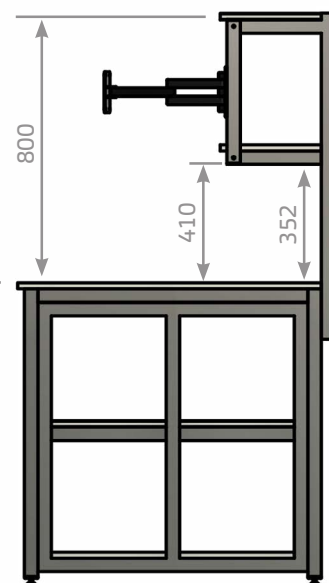
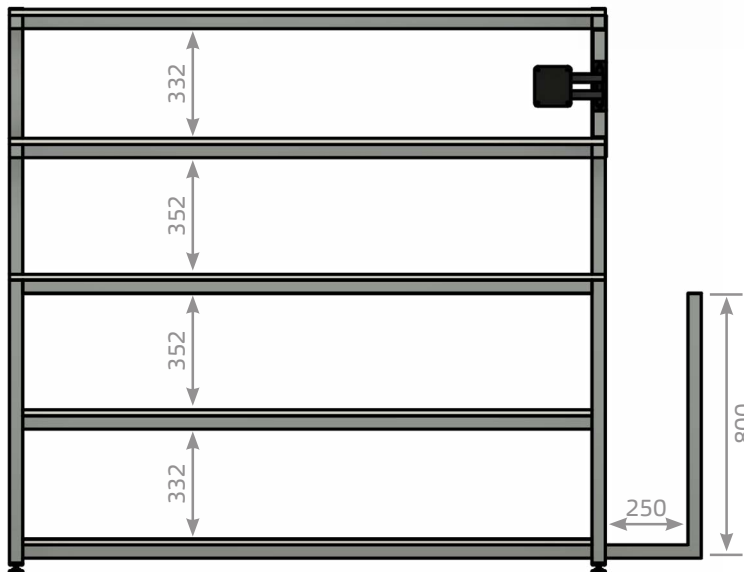
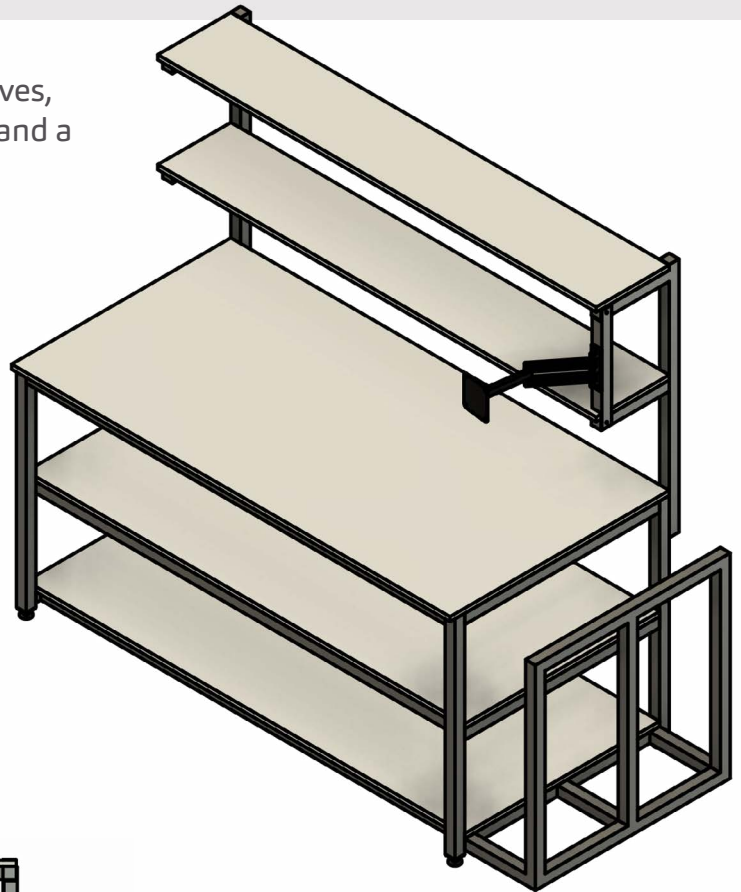

Pack Bench Safe Weight: Lower Shelves 100kg per shelf, Worktop 150kg, Top Shelves 75kg per shelf



# Part Options

1	<b>Under worktop divider</b> 800mm deep x 400mm high	WSP01
2	<b>Box divider small*</b> 302mm deep x 250mm high	WSP02
3	<b>Roll holder*</b> Up to 150mm diameter roll on a 75mm core	WSP03
4	<b>Monitor arm fixed height</b> 75mm and 100mm versa mount Max 20KG	WSP04
5	<b>Keyboard dropper</b> To fit standard keyboard Adjustable to slope keyboard	WSP05
6	<b>Adjustable monitor arm</b> Fixed angle monitor and keyboard position Unit will swing left and right and fix in position	WSP06
7	<b>Drawer*</b> 400mm wide x 601mm deep x 200mm high	WSP07
8	<b>Braked castors</b> 125mm wheel Locking swivel, free swivel, fixed positions	WSP08
9	<b>Cutter for bubble / film</b> Will cut up to 500mm wide rolls Bench mount or free standing	WSP09
10	<b>Data socket</b> 2 gang supplied unfitted	WSP10

11	<b>4 data socket</b> 4 gang supplied unfitted	WSP11
12	<b>Desk tidy insert round</b> Inc fitting into worktop	WSP12
13	<b>Mains twin 13A socket</b> 2 gang mains unfitted	WSP13
14	<b>Desk cable tidy rectangle</b> Fitted in worktop Can be used as bin hole	WSP14
15	<b>Dado trunking</b> Fitted to bench 1800mm	WSP15
16	<b>Roll holder fixed</b> For tape and stickers - 260mm wide Fitted under shelf or worktop	WSP16
17	<b>Adjustable tray</b> 400mm x 200mm Unit will swing left and right and fix in position	WSP17
18	<b>Dunnage dispenser</b> Adjustable arm dunnage holder for centre pull rolls	WSP18
19	<b>Shelf</b> 498mm wide x 199 deep Needs to fit off a back board or mid over shelf	WSP19
20	<b>Bubble holder*</b> Hold rolls up to 500mm wide To fit 300mm or 400mm top shelf	WSP20

\*Made from powder coated steel, Ral7001

Find out how our modular customisable benches could work for your operation.

Contact us now at [enquiries@southgateglobal.com](mailto:enquiries@southgateglobal.com).



Manufactured to order  
in Great Britain

